



Lake View Terrace Library. Lake View Terrace, California, USA. Architect: Fields Devereaux Architects & Engineers. Electrical engineer: Fields Devereaux Architects & Engineers. Sustainable Design Consulting and Commissioning: GreenWorks Studio. Photo: Frank Domin

Weblink 1390

Design

Louis Poulsen Lighting A/S

Concept

Airport provides high-ceiling spaces with general lighting, both as direct and indirect light. Depending on the surface of the large reflector, the light will either have a wide or a narrow beam spread.

Finish

White, powder coated. Anodised aluminium.

Material

Reflector: Spun anodised aluminium. Bottom cup: Die cast aluminium. Housing: Die cast aluminium. Pendant tubes: Polished stainless steel.

Mounting

Suspension type: Cable 3x0.75mm² & wire. Canopy: No. Cable length: 4m.

Weight

Max. 11.5kg.

Class

Ingress protection IP20. Electric shock protection I w. ground. ⚡

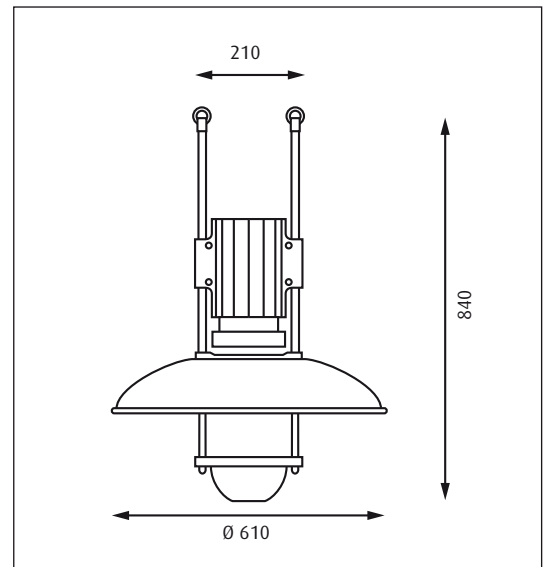

Product code	Light source	Finish	Reflector	Cable type
AIR-P	1x150W HIT-DE Rx7s-24 HF 1x500W QT-DE 12 Clear R7s	WHT	NARROW WIDE	WHT PL/WIRE

Info notes:

Reflector wide beam: white. Reflector narrow beam: aluminium. HIT-version phase-compensated.



Narrow
beam



Wide beam