



**Weblink**  
1520

**Project page**  
268, 274, 368

Dansk Design Center. Copenhagen, Denmark. Architect: Henning Larsen. Photo: Anders Sune Berg

## Design

Shoichi Uchiyama

## Concept

Enigma 825 emits glarefree light of high quality. The illumination of the seven shades gives a floating and sculptural character.

## Finish

Aluminium, brushed & anodised. Matt acrylic.

## Material

Cone: Natural anodised brushed aluminium. Wire: Stainless steel. Shades: Matt acrylic. Pendant tube: Extruded aluminium, brushed & anodised.

## Mounting

Suspension type: Cable 3x0.75mm<sup>2</sup> & wire. Canopy: Yes. Cable length: 1,5m (HIT) or 4m (QT).

## Weight

Max. 7kg.

## Class

Ingress protection IP20. Electric shock protection I w. ground. ⚡

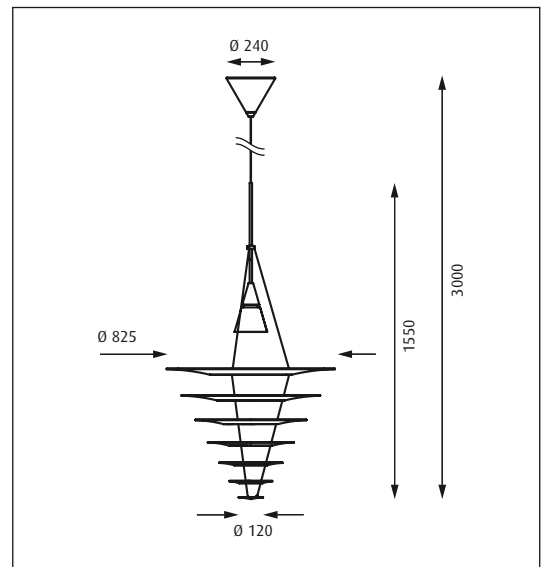

Product code	Light source	Finish	Cable type
ENIG-825-P	1x35W HIT-CRI G12 HF 1x70W HIT-CRI G12 HF 1x150W QT Clear E27	ALU BR. & ANO	WHT TEX/WIRE

Info notes:  
For higher ceiling heights and when using HIT a special accessory is available.

